

# MAKELSON<sup>®</sup>

Uninterruptible Power Supplies

## USER MANUAL

### MRG/MST33 SERIES

### STATIC VOLTAGE REGULATOR

### 200-300-400-500 KVA

AG-SD-117

Rev. No:0/Rev. Date:

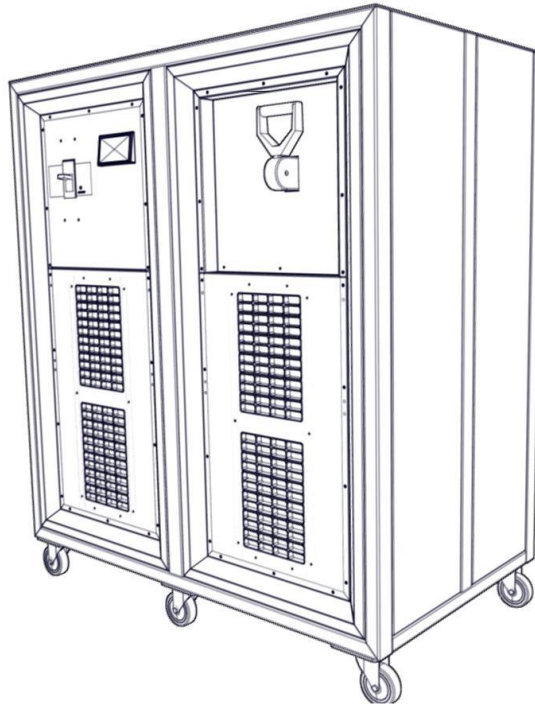



**USER MANUAL**  
**MRG/MST33 SERIES**  
**STATIC VOLTAGE REGULATOR**  
**200-300-400-500 KVA**

## About the Manual

This Manual is prepared for the users of MRG/MST33 Series 200-300-400-500 KVA static voltage regulator.

### Companion Manuals

For more info about this device and its options, please visit [www.makelsan.com.tr](http://www.makelsan.com.tr)

### Updates

Visit [www.makelsan.com.tr](http://www.makelsan.com.tr) for updates. Always use the latest manual.

## Shipment

Carrying vehicles or handling accessories must have enough features and characteristics to carry UPS's weight.



**DO NOT LIFT HEAVY DUTY WEIGHT WITHOUT HELP**



<18 kg (<40 lb)



32–55 kg (70–120 lb)



18–32 kg (40–70 lb)



>55 kg (>120 lb)



**CONTENTS**

1 SAFETY AND WARNINGS..... 1

1.1 Warnings..... 1

1.2 Clearance and Access..... 2

1.3 Storage..... 2

1.4 Shipment..... 2

2 PRODUCT DESCRIPTION..... 3

2.1 General Information..... 6

2.2 Regulators Operation Modes..... 6

2.2.1 Normal Mode..... 6

2.2.2 Mechanical Bypass Mode..... 6

2.3 User Panel..... 7

2.3.1 Opening Screen..... 8

3 INSTALLATION..... 9

3.1 Warnings..... 9

3.2 Pre-installation check up..... 9

3.3 Positioning..... 9

3.4 Transportation Type of Cabinets..... 10

3.5 Mains and Load Connections..... 10

3.5.1 External Protection..... 10

3.5.2 Cabling and fuse configuration..... 11

3.5.3 Cable connections..... 12

4 OPERATION..... 14

4.1 Operation Procedure..... 14

4.1.1 Circuit Breakers..... 14

4.1.2 First start-up..... 14

4.1.3 Setting Mechanical Bypass..... 15

4.1.4 Performing a Complete Shutdown..... 16

4 TABLE of TECHNICAL SPECIFICATIONS..... 17

6 GUARANTEE..... 19

6.1 Terms of Guarantee..... 19

6.2 Cases Not Covered by the Guarantee..... 20

7 CONTACT INFORMATION..... 22

# 1 SAFETY AND WARNINGS

## 1.1 Warnings

This manual must be read before installing the MRG/MST33 series voltage regulator. The device can be installed and started only by Makelsan authorized personnel.

Installation or start-up by unauthorized personal may cause damage to the device and serious injury or death.

The regulator is designed to be used in continuous vertical fixed position applications.



**THE REGULATOR MUST BE USED WITH GROUND CONNECTION.**

Connect the ground cable before connecting the mains.

Ground currents may be as high as 30mA



**THE INPUT BREAKER MUST BE SET OFF POSITION, THE VOLTAGE REGULATORS MAIN/REGULATOR BREAKER MUST SET THE "0" POSITION BEFORE MAINTENANCE.**

## Service-Maintenance

All servicing and maintenance is done internally. All parts in the device can be serviced and replaced only by a trained technician.



**Preventative maintenance is recommended at least once a year from the installation by authorized technical personnel. (This service will be provided for a fee by our authorized MAKELSAN personnel.)**

Fire extinguishing equipment must be kept nearby the regulator.

## 1.2 Clearance and Access

### Clearance

There must be spaces at least 1 meter for regulators fans around. Should not be permanent or temporary use within the limits specified. Otherwise, the regulator performance will decrease.

### Access

Operator reaches regulator via front, side and top panel on 200-300-400-500 kVA regulator, enough area must be left for operator.

## 1.3 Storage

Regulator should be kept in a room or area where is protected from excessive moisture and heat before commissioning. Regulator cabinets must be kept in the original packaging.

## 1.4 Shipment

Carrying vehicles must have be equipped properly and have features and characteristics sufficient to carry regulator.

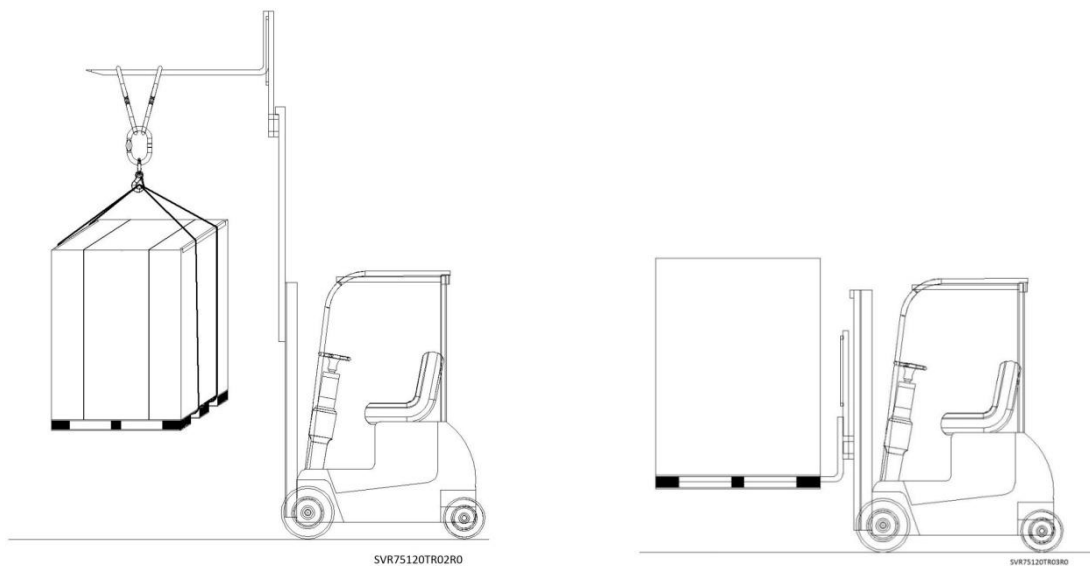

The regulator device shipment must be done on pallets.

Cabinet is equipped with four-wheel. In this way, it can be placed by moving easily. These wheels are to be used on smooth surfaces only.

The front wheels of regulator must be locked after positioning properly. The rear side wheels are fixed.

Move the regulator as rarely as possible.

## 2 PRODUCT DESCRIPTION

Makelsan MRG/MST33 static voltage regulators are extensive input voltage ranged regulator which controlled by microprocessor. MRG/MST33 are high efficiency and high speed static voltage stabilizers.

### General View

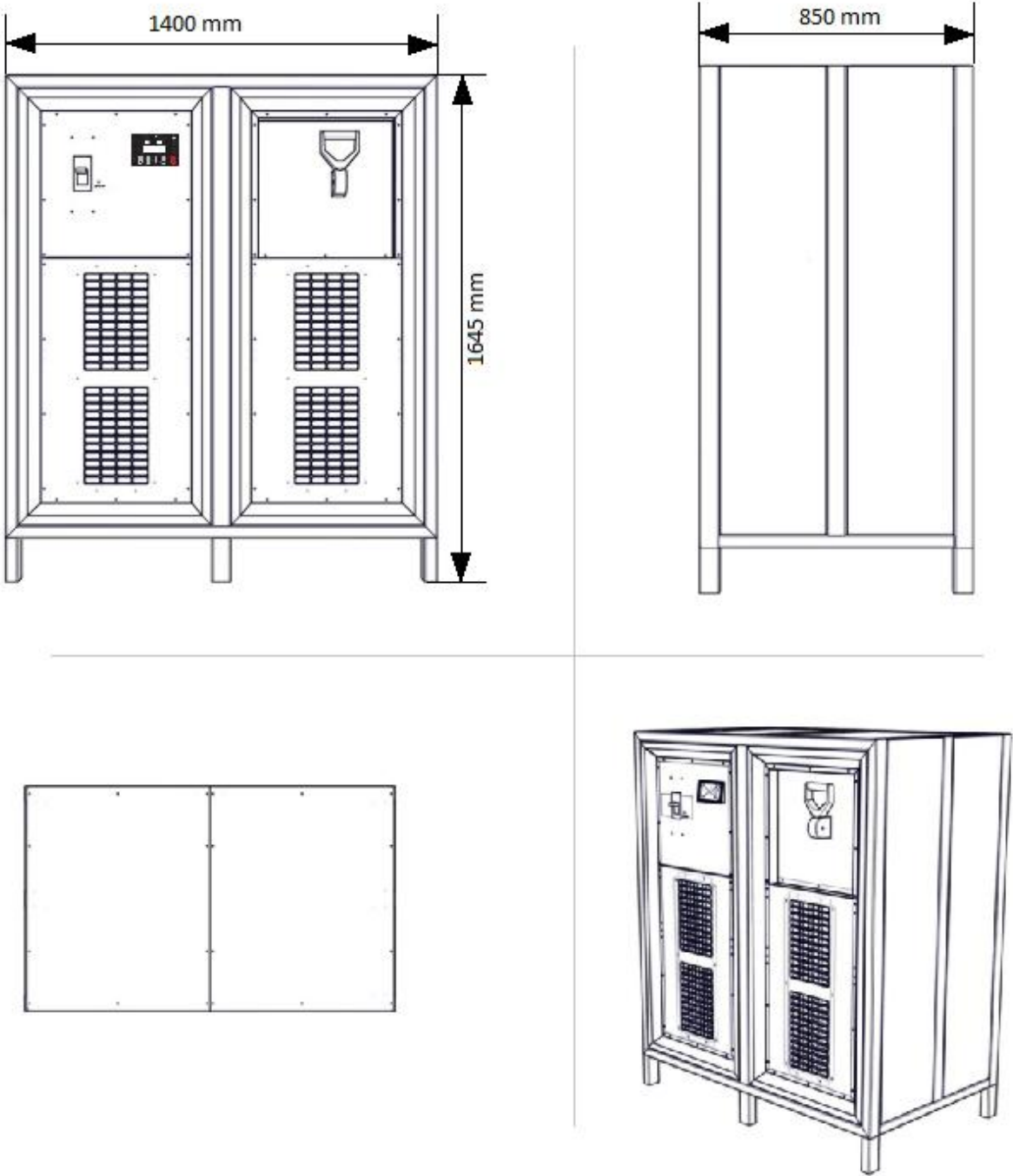



Front View

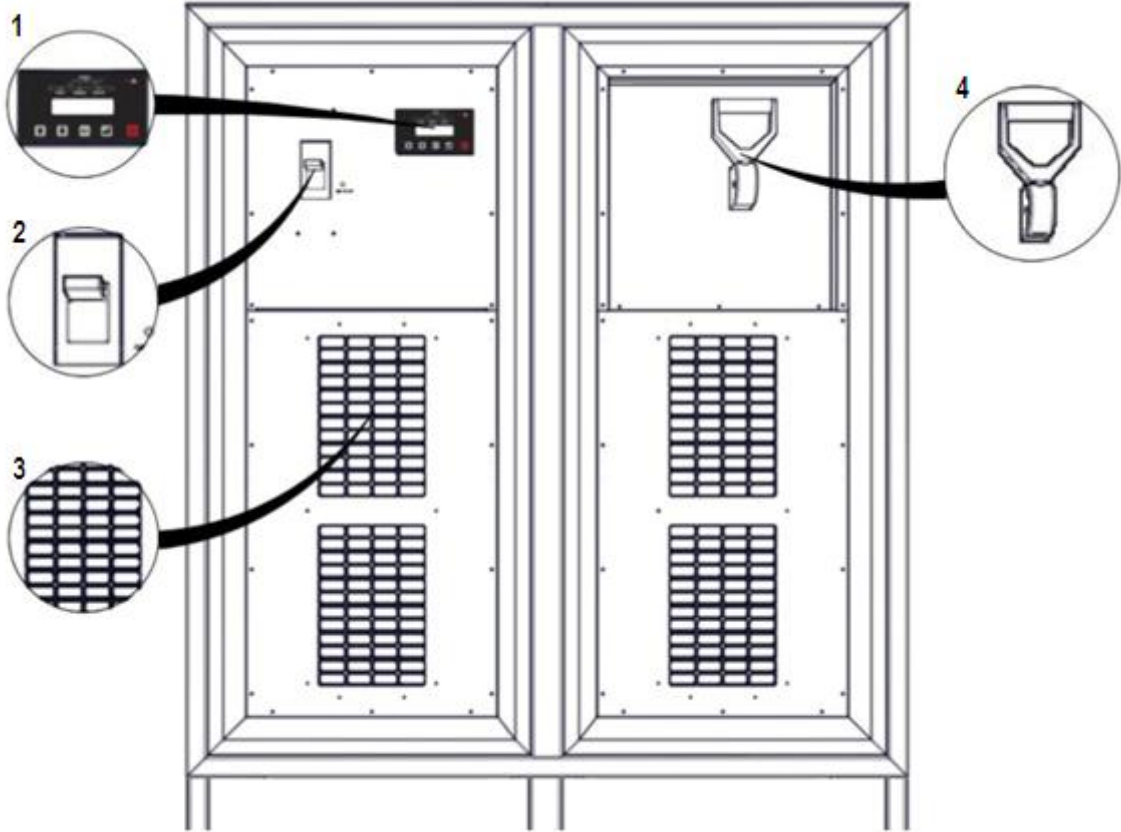

1	Users Panel
2	Input Breaker
3	Evacuation Channel
4	Bypass/Regulator Breaker

Rear View



1	Main Connectors Terminal
2	Load Connectors Terminal

## 2.1 General Information

General operation topology of MRG/MST33 Series can be recognized as follows:

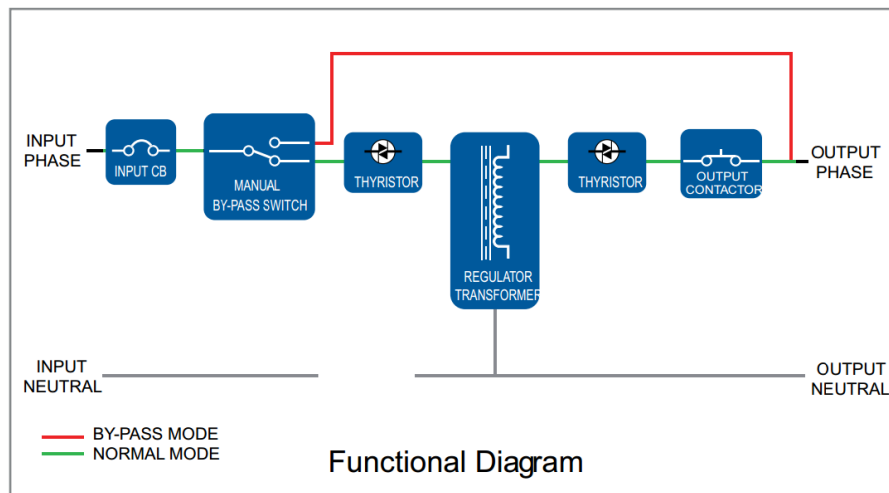

MRG/MST33 Series Static Voltage Regulator Functional Diagram

MRG/MST33 Series Static Voltage Regulator (SVR) transfers the electrical energy from the main supply to output and monitors output voltage magnitude continuously.

If there is a distortion in the output voltage according to a desired output voltage value, the microcontroller unit selects the appropriate input-output windings of the transformer immediately and then semiconductor power switches (thyristors) and ends of the windings connect the SVR input-output for stay in appropriate values.

Thus Static Voltage Regulator (SVR), the voltage magnitude of the corresponding additional energy generated by the electrical energy received from the network, by adding to its network voltage amplitude (or removing) obtains an output voltage magnitude between set points

## 2.2 Regulators Operation Modes

MRG/MST33 series operated in the following modes:

- Normal Mode
- Mechanical Bypass Mode

### 2.2.1 Normal Mode

In this mode, regulator feeds the load through the regulated voltage.

### 2.2.2 Mechanical Bypass Mode

Operator sets main position to Main/Regulator breaker for operating mechanical bypass mode. In this mode; the maintenance bypass load is directly or mains power for the loss of energy of the load during faults

## 2.3 User Panel

User panel consists of mimic diagram, LCD screen, ON/OFF button and menu keys. The regulator can be controlled via this panel.

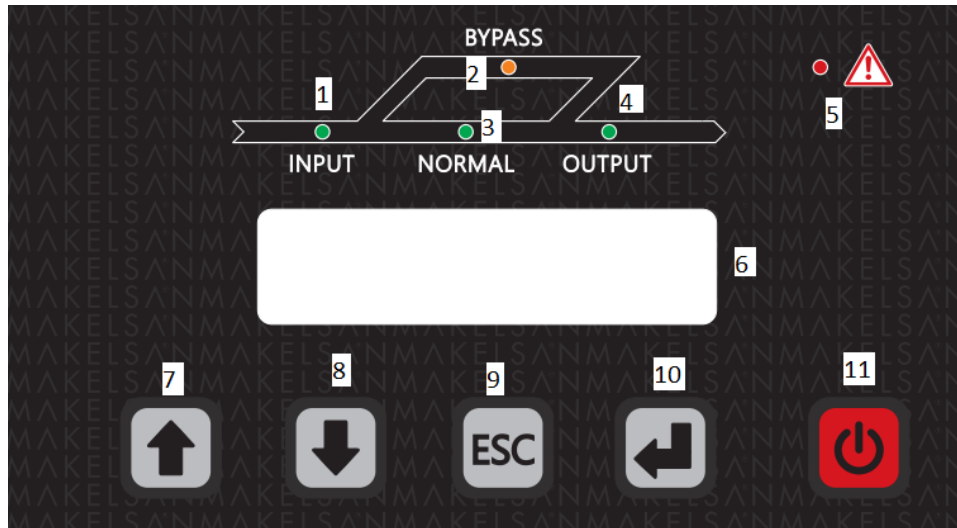

1	<b>Input Led:</b> Flashes while the main within out of limits. Illuminates when main is normal.
2	<b>Bypass Led:</b> Illuminates while the loads are fed through bypass line.
3	<b>Normal Led:</b> Illuminates while the loads are fed through regulator works.
4	<b>Output Led:</b> Flashes while the main within the limits and output breaker works.
5	<b>Alarm/Warning Led</b>
6	<b>LCD Display</b>
7-10	<b>Menu Keys</b>
11	<b>ON/OFF Button</b>

### Menu Flow Chart

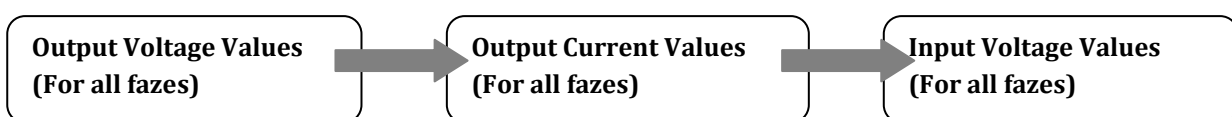

### 2.3.1 Opening Screen

When the front panel monitor is turned on, firstly opening screen is observed. Output voltage, output current, input voltage (for all fazes) can be observed here. If no button is pressed for 5 minutes, system returns to the opening screen. Use up and down keys to see output voltage, output current and input voltage.

- **Output Voltage (L1, L2, L3)**

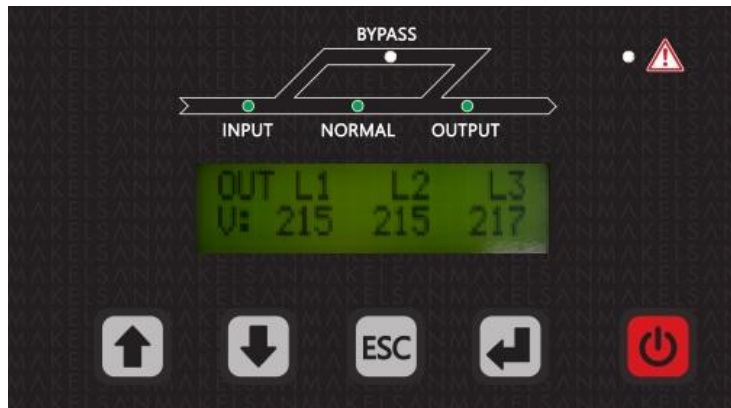

- **Output Current (L1, L2, L3)**

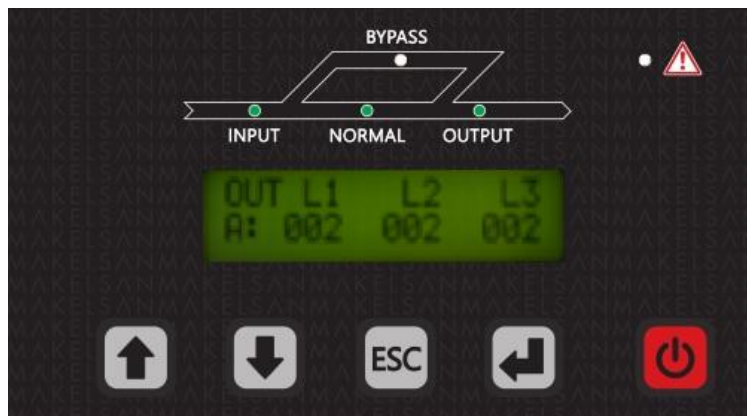

- **Input Voltage (L1, L2, L3)**

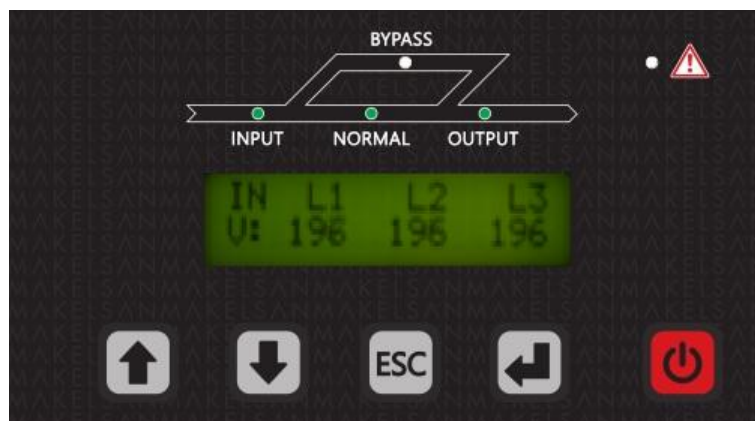

## 3 INSTALLATION

This section contains the warnings and control actions that must be performed before the REGULATOR start-up. Additionally, you will find here important information about the REGULATOR cabins transportation, positioning and connections.

### 3.1 Warnings



**The regulator must be installed by a certified electrician of Makelsan.  
The warranty is valid only for the regulator installed by a certified electrician of Makelsan.**

Proper safety gear must be used to protect the skin and the eyes from electrical arcs.

ESD-protected rubber gloves should be used.

Remove any metal accessories (ring, watch, etc.) before working on the device.

Regulator needs three phase and four cable (+ground) supply system for input. This supply system type is confirmed as IEC60364-3 standards.

### 3.2 Pre-installation check up

Before installation of the regulator the following control actions must be taken, these first and most important steps will secure the accurate operation of the product.

- Check if any damage was done to the regulator during transportation. Report any damages instantly.
- Make sure that model power rating is right. Check the regulator label for the actual power rating.

### 3.3 Positioning

The regulator is designed for the indoor use. Keep the device in a cool and dry place, with the air flow, humidity and temperature values must be within the specified range.

In the 200-300-400-500kVA MRG/MST33 series, fresh air enters the device from the front and goes out from the fans on the rear side of the device. Care must be taken in order not to cover the air entrance and exit spots. Regulator must be positioned on a place where it is protected from water etc. contact risks.

If the area is dusty, optional filters must be used for such environment. These filters usage must be done as per instructions document.

Climate must be provided to reach the maximum level of performance of regulator.

### 3.4 Transportation Type of Cabinets

Carrying vehicles or handling accessories must have enough features and characteristics to carry regulator's weight.

Cabinet is equipped with four-wheel. In this way, it can be placed by moving easily. These wheels are to be used on smooth surfaces only.

### 3.5 Mains and Load Connections

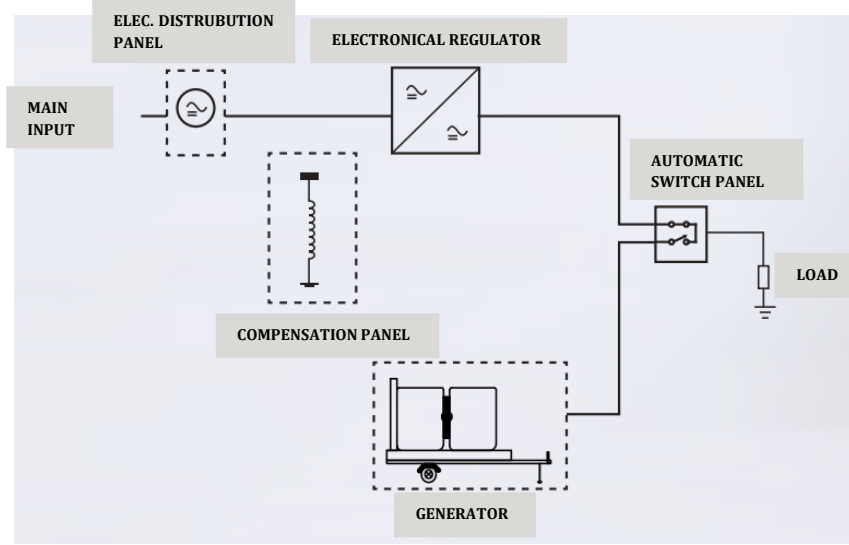

Recommended connections of MRG/MST33 Series Static Voltage Regulator

#### 3.5.1 External Protection

To protect the AC inputs, thermal magnetic breakers or V type breakers must be installed on the distribution board.

Over current protecting must be installed on mains input distribution board and fuses must be chosen 135% higher rated than the ones given in the table below. Fuses must be C-type.

Ground leakages flow to the ground through the EMI filters on the input and the output of the regulator. Makelsan recommends the use of 30mA rated relays for handling leakage currents.

Those relays must also be:

- Resistant to both positive and negative DC pulses,
- And not sensitive to transient currents.
- Must be sensitive to currents which is average between 0,03-1 A.

### 3.5.2 Cabling and fuse configuration

Full load input and output currents must be reviewed for proper cabling and fuse selection.

\*For standard model SVR

Regulator Power	Input Cable Size(mm <sup>2</sup> )	Output Cable Size(mm <sup>2</sup> )	Ground Cable Size(mm <sup>2</sup> )	Input Fuse Value	M. Bypass Fuse Value	Output Fuse Value
<b>200KVA</b>	4×150	4×150	1×150	3×400A	4×250A	3×250A
<b>300KVA</b>	4×240	4×240	1×240	3×630A	4×400A	3×400A
<b>400KVA</b>	4x(2x150)	4x(2x150)	2x150	3×800A	4×500A	4×500A
<b>500KVA</b>	4x(2x185)	4x(2x185)	2x185	3x1000A	4×630A	4×630A

The length of the cable must not be over 5 meters. Maintenance bypass fuse that is only for using by Makelsan service technician and have to be locked.

\*For large input voltage range SVR

Regulator Power	Input Cable Size(mm <sup>2</sup> )	Output Cable Size(mm <sup>2</sup> )	Ground Cable Size(mm <sup>2</sup> )	Input Fuse Value	M. Bypass Fuse Value	Output Fuse Value
<b>200KVA</b>	4×240	4×150	1×150	3×630A	4×250A	3×250A
<b>300KVA</b>	4x(2x150)	4×240	1x240	3×800A	4×400A	3×400A
<b>400KVA</b>	4x(2x240)	4x(2x150)	2x150	3x1000A	4×500A	4×500A
<b>500KVA</b>	4x(3x185)	4x(2x185)	2x185	3x1250A	4×630A	4×630A

The length of the cable must not be over 5 meters. Maintenance bypass fuse that is only for using by Makelsan service technician and have to be locked.

It should be noted that with non-linear loads, neutral current may rise up to 1.5 times the phase current



### 3.5.3 Cable connections

All electrical connections of the regulator are made from the front side of the device.



**ATTENTION! 3 pole-circuit breakers (switch) are used for the input and output of regulator, Neutral line must not be interrupted.**

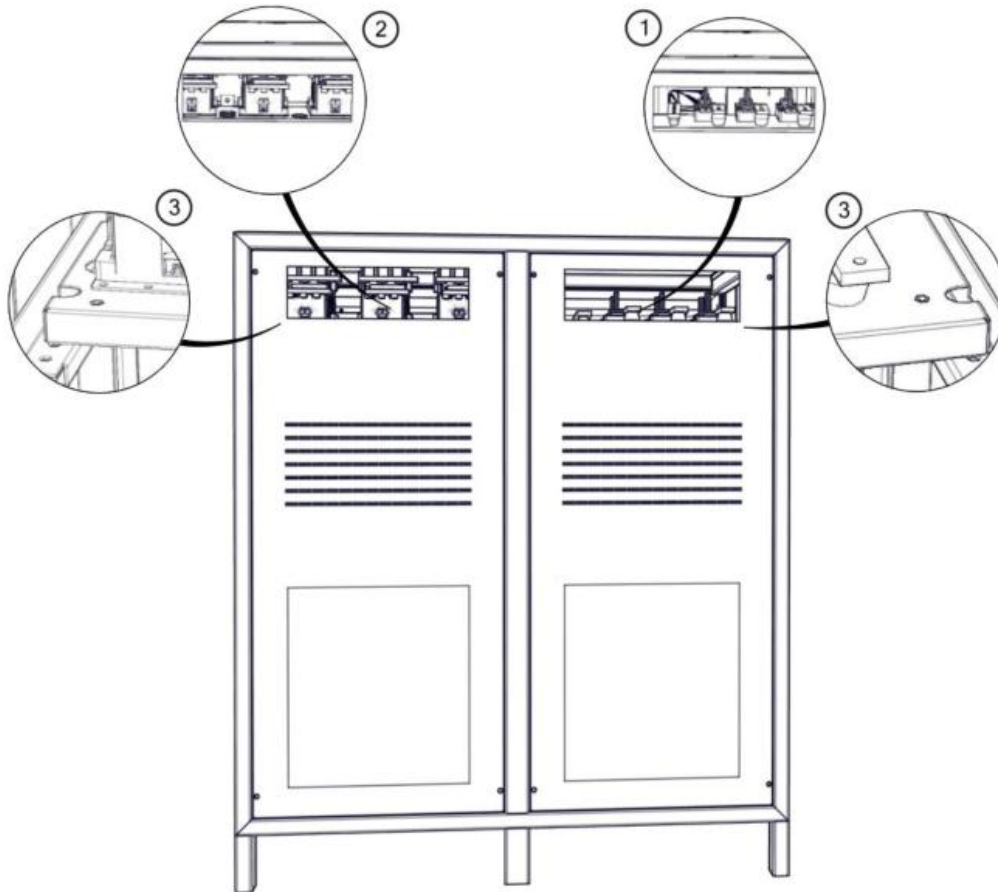

<b>1</b>	Main Connectors Terminal
<b>2</b>	Load Connectors Terminal
<b>3</b>	Ground Connection

#### Electrical Connections

Read the following steps to connect the cables properly:

1. Turn **OFF** all the distribution board breakers (both input and output distribution boards) to make sure that the load and mains are completely disconnected from any cable.
2. Remove the cover to make the regulator wiring connection ,
3. Connect the ground cable.

4. Make sure that the circuit breakers are **OFF**. The use of these circuit breakers is explained on the operation section.

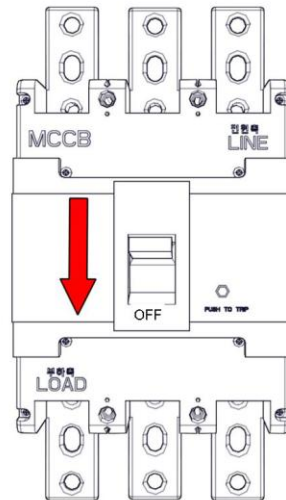

Input breakers is OFF position.

5. Connect the input cables;
  - R to INPUT L1,
  - S to INPUT L2,
  - T to INPUT L3,
  - N (Neutral) to INPUT N.
6. Check the phase sequence.
7. Repeat steps 4-5 for output cables.



**Make sure that the loads are isolated from the regulator output if they are not ready to be connected.**



**Make sure that the cables are connected properly before regulator is started. Additionally, check if there is galvanic isolation transformers at input of regulator and consider the local directions.**



**Check the grounding before starting the regulator. Wrong works or grounding on regulator or other devices of installation may be hazardous. Wrong works and grounding may damage regulator and another system on the installation.**

## 4 OPERATION

### 4.1 Operation Procedure

You can find information about circuit breaker, first start-up, setting mechanical bypass, turning regulator off in this section.

#### 4.1.1 Circuit Breakers

There are 1 input breaker (CB1) and one main/regulator choosing breaker (CB2) on the front side of the regulator.

#### 4.1.2 First start-up

1. Turn all circuit breakers OFF position.
2. Take the main supply/regulator selector switch sets REGULATOR position. Regulator will operate normal mode. (all 3 phases will start up)

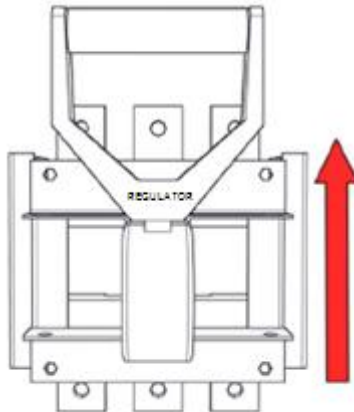

3. Take Input breaker ON position.

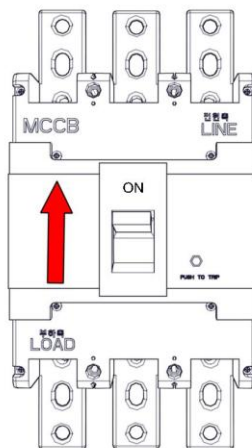

4. Check the regulator has switched to normal operation mode, via mimic diagram LEDs and LCD panel.
5. The loads which are connected to regulator can be turned on.

After all these steps, check that load is fed through regulator via mimic diagram. In a contrary situation, check regulator total and phase loads.

#### 4.1.3 Setting Mechanical Bypass

When the voltage regulator to do maintenance or experiencing a fault condition on the mechanical bypass mode, power is transferred from the main.

For this; loads in the voltage regulator output is disabled. Input switch sets OFF.

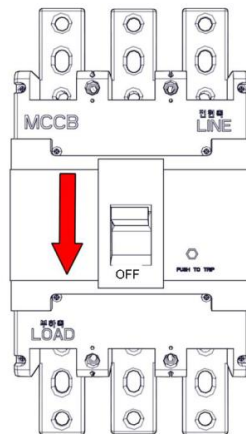

The main supply / regulator selector switch sets "MAIN" position. Then input switch sets ON again.

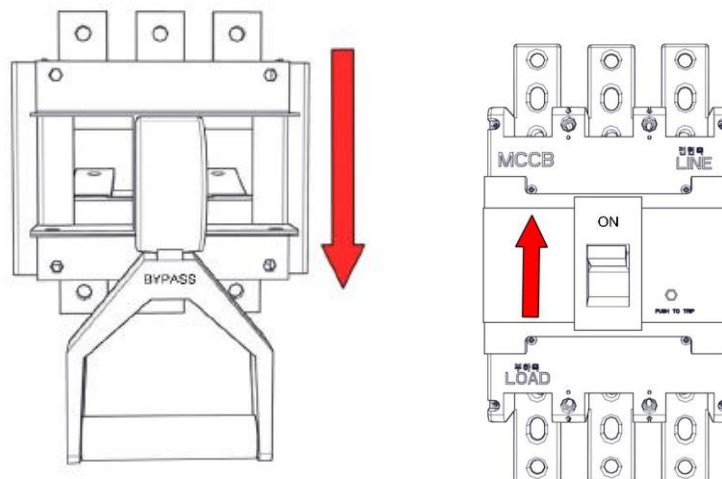

#### 4.1.4 Performing a Complete Shutdown

1. Turn off the loads connected to the device.
2. Turn OFF respectively the input breaker and the main supply / regulator selector switch breakers.

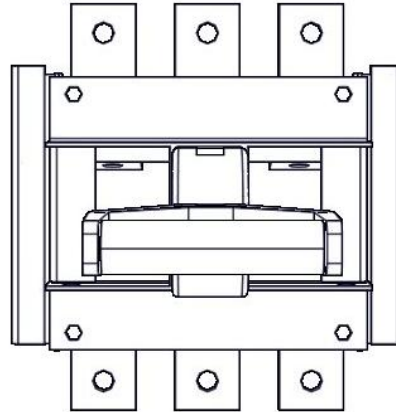
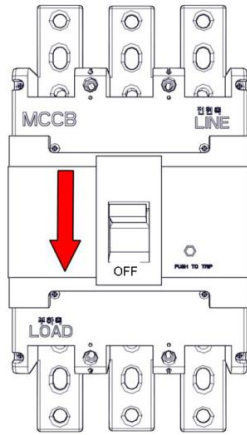

**MAKE SURE THAT THERE ARE NO CRITICAL LOADS ON THE REGULATOR OUTPUT BEFORE PERFORMING A COMPLETE SHUTDOWN.**

## 5. TABLE of TECHNICAL SPECIFICATIONS

- For standard voltage regulator

MODEL	MRG3/MST30200	MRG/MST330300	MRG/MST330400	MRG/MST330500
Capacity (kVA)	200	300	400	500
<b>INPUT</b>				
Input Voltage	380 VAC (phase-phase)			
Input Voltage Correction Interval	275-450 VAC (phase-phase)			
Operation Frequency	50Hz $\pm$ 10%			
Input Current (Max.)(A)	340	510	680	850
<b>OUTPUT</b>				
Output Voltage	380 VAC (phase-phase)			
Output Voltage Tolerance	$\pm$ 5%			
Correction Speed	500 V/sn			
Output Frequency	Same as mains			
Output Current (A)	242	363	484	606
Overloading	125% : 10minute, 150% : 1minute.			
Output Protection	Short Circuit, over-load, over-temperature, over and low voltage protections			
<b>GENERAL</b>				
Topology	Microprocessor controlled, semi conductor electronic static structure			
Total Efficiency	>97%			
Mechanical By-Pass	Main/regulator choosing breaker			
Display	2x16 LCD Display			
Working Temperature	0°C~40°C			
Storage Temperature	-25°C~60°C			
Protection Level	IP20			
Cabin Colour	Anti-Static paint protection RAL 9005			
Relative Humidity	%0-95			
Working Altitude	<1000m			
Acoustic Level	<50dB			
Net Weight	636	775	857	930
Dimension (WxDxH) (mm)	1400x850x1645			

MRG/MST33 Series STATIC VOLTAGE REGULATOR 200-300-400-500kVA

- For Wide -range input voltage regulator

MODEL	MRG3/MST30200	MRG/MST330300	MRG/MST330400	MRG/MST330500
Capacity (kVA)	200	300	400	500
<b>INPUT</b>				
Input Voltage	380 VAC (phase-phase)			
Input Voltage Correction Interval	190-476 VAC (phase-phase)			
Operation Frequency	50Hz ±10%			
Input Current (Max.)(A)	505	758	1010	1263
<b>OUTPUT</b>				
Output Voltage	380 VAC (phase-phase)			
Output Voltage Tolerance	±5%			
Correction Speed	500 V/sn			
Output Frequency	Same as mains			
Output Current (A)	242	363	484	606
Overloading	125% : 10minute, 150% : 1minute.			
Output Protection	Short Circuit, over-load, over-temperature, over and low voltage protections			
<b>GENERAL</b>				
Topology	Microprocessor controlled, semi conductor electronic static structure			
Total Efficiency	>97%			
Mechanical By-Pass	Main/regulator choosing breaker			
Display	2x16 LCD Display			
Working Temperature	0°C~40°C			
Storage Temperature	-25°C~60°C			
Protection Level	IP20			
Cabin Colour	Anti-Static paint protection RAL 9005			
Relative Humidity	%0-95			
Working Altitude	<1000m			
Acoustic Level	<50dB			
Net Weight	636	775	857	930
Dimension (WxDxH) (mm)	1400x850x1645			

## 6 GUARANTEE

### 6.1 Terms of Guarantee

- Our products are under a two-year guarantee starting from the date of delivery against malfunctions resulting from production, material and workmanship faults. Malfunctions due to such type of faults will be removed without claiming any price of workmanship or spare parts to be replaced.
- Whether aforementioned malfunctions originate from usage faults or not are determined with a report to be issued by service stations, if there exists no service stations, by one of seller, dealer, agency, representative, importer or manufacturer or producer of those products respectively.
- Repair time of defective products is twenty business days at most. This period starts from the date when products are delivered to one of seller, dealer, agency, representative, importer or one of manufacturer or producer. Provided that products break down within the period of guarantee, the time passing during the repair process is added to the guarantee time. Provided that faults of products cannot be removed within ten business days, manufacturer-producer or importer is obliged to assign another product having similar features for the use of consumers until the faulty product has been repaired.
- Even though consumers exercise their repair rights, they can claim free replacement of products, refund or price discount at the rate of fault in the events;
  - That, besides, the product, as of the date when the product is delivered to the consumer, breaks down four times a year or six times within the guarantee period to be determined by the manufacturer-producer and/or importer at least, on the condition of being in guarantee period, such malfunctions perpetuate passing over;
  - That maximum time required for the repair of products is exceeded;
  - That repair of the malfunction is determined as impossible through a report to be issued by service station, if there exists no service station, one of seller, dealer, agency, representative, importer or manufacturer or producer of the company respectively.
- The consumer is, on demand, obliged to submit guarantee certificate in terms of repairs or replacements within the scope of guarantee.
- It is essential that you definitely perform damage control over external packaging before receiving the products to be sent through freight. In the event of any damage, delivery person must be made to prepare a “damage determination record”. (For example; during the delivery process, the product has been checked and seen that is damaged.)



- After the damage determination record has been issued, we request you to inform the MAKELSAN head office of the case. Products to be received from freight by signature means that products have been received completely and without no damage.
- Repairs of plug-and-play products in the places where no service point is around are performed in the factory of MAKELSAN or the nearest service point according to the direction to be made by the MAKELSAN head office. Defective product is delivered by hand to the nearest service point or to the contracted freight company in its original packaging to be sent to the factory of MAKELSAN according to the direction to be made by the MAKELSAN head office. For malfunctions in the scope of guarantee, shipment fees are under the responsibility of MAKELSAN on the condition that products are delivered to the contracted freight company.
- The device must be sent as packed in its original packaging as long as it is not desired by the service. Original packaging of devices should be preserved in order to use them for shipment of devices in terms of repairs to occur. Otherwise, no responsibility is assumed with regards to any troubles to be experienced.
- All defective products to be delivered by hand or through freight are to meet the necessary shipment requirements. (Anti-static protective, bubble wrap or box etc.) It is essential that legible barcode serial number belonging to the product be on the product. Otherwise, it is not covered in the scope of the guarantee.
- It is essential that products to be sent through freight definitely be together with delivery note, and that serial/model/malfunction details be written on delivery note to be sent (for example, breakdown report form), and that packaging content match with the products specified in the delivery note. Otherwise, freight is not accepted.
- The use of Guaranty Certificate, submitted together with product with MAKELSAN trademark, is agreed and committed to the protection of consumer law with no 6502, that accordancy with Regulation of the Warranty no 29029.

## **6.2 Cases Not Covered by the Guarantee**

- Breakdowns resulting from the use of products contrary to the issues or the environment conditions (temperature, humidity etc.) specified in the user manual are not covered in the scope of guarantee.
- Damages and breakdowns resulting from the use of software, hardware, interface, accessories or consumables apart from those used together with products or recommended ones; changing place, wrong and insufficient maintenance, calibration or use; its operation contrary to environment specifications published for products; insufficiency of air installation; use of products in ambient having excessive humid or temperature; its operation in environment harmful for electrical circuits and abrasive; and accidents, impacts, electric, shipment, natural disasters, not limited to the ones listed above, are not covered in the scope of product guarantee.

- In the general examination performed during the breakdown acceptance process, certain troubles causing products not to be covered in the scope of guarantee might not be understood. Provided that such faults come up in the detailed examination to be performed via technical service equipment, products are returned to customers.
- Products not covered in the scope of guarantee can, on demand of customer, be treated in a fee-paying way within the bounds of possibilities of the authorized service. Products out of the scope of guarantee, repairs of which are not possible are returned to customers.
- Damages and breakdowns resulting from treatments, internally or externally tampering, efforts to repair and spare part replacement of products, without approval of MAKELSAN, and those resulting from treatment of unauthorized service/dealer/person/establishment, are not covered in the scope of guarantee. Breakdown, cracks, scratches and wear, corrosion and dust to occur in time and by use in the outer surfaces of products (cabinet, cover, and front panel) are not covered in the scope of guarantee.
- In the event that original serial numbers, guarantee labels and stamps on products are removed or distorted, products are not covered in the scope of guarantee. No guarantee is issued against the use of products for any other purpose, apart from those specified in introduction or manual of products.
- Shelf lives of VRLA batteries are 6 months under the ambient temperature of 15 °C and 3 months under the ambient temperature of 25 °C.
- It is compulsory that systems to be purchased be commissioned within 3 months

## 7 CONTACT INFORMATION



[www.makelsan.com.tr](http://www.makelsan.com.tr)

**Headquarter:** İstanbul Deri Organize Sanayi Bölgesi 2. Yol I -5 Parsel 34956 Tuzla/ İstanbul

Tel : 0216 428 65 80

Fax : 0216 327 51 64

E-mail : [makelsan@makelsan.com.tr](mailto:makelsan@makelsan.com.tr)

**İzmir Office :** Halkapınar Mah. 1348 Sok. 2AE Keremoğlu İş Merkezi Yenişehir – İzmir

Tel : 0232 469 47 00

Fax : 0232 449 47 00

E-mail : [izmir@makelsan.com.tr](mailto:izmir@makelsan.com.tr)

**Ankara Office :** Mustafa Kemal Mah. 2157 Sok. No:4/6 Çankaya-Ankara

Tel : 0312 219 82 35/37

Fax : 0312 219 82 36

E-mail : [ankara@makelsan.com.tr](mailto:ankara@makelsan.com.tr)

# MAKELSAN®

Uninterruptible Power Supplies

[www.makelsan.com.tr](http://www.makelsan.com.tr)

**Headquarter:** İstanbul Deri Organize Sanayi Bölgesi 2. Yol I -5 Parsel 34956 Tuzla/ İstanbul

Tel : 0216 428 65 80

Fax : 0216 327 51 64

E-mail : [makelsan@makelsan.com.tr](mailto:makelsan@makelsan.com.tr)

**İzmir Office :** Halkapınar Mah. 1348 Sok. 2AE Keremoğlu İş Merkezi Yenişehir – İzmir

Tel : 0232 469 47 00

Fax : 0232 449 47 00

E-mail : [izmir@makelsan.com.tr](mailto:izmir@makelsan.com.tr)

**Ankara Office :** Mustafa Kemal Mah. 2157 Sok. No:4/6 Çankaya-Ankara

Tel : 0312 219 82 35/37

Fax : 0312 219 82 36

E-mail : [ankara@makelsan.com.tr](mailto:ankara@makelsan.com.tr)